

We truly believe in *perfection*



ISO 9001:2015 CERTIFIED

Knox[®]
ELECTRONICS

IS9281:PART-3:1981

CM/L7800023609

Rudra

House of Weighing...

The company is proud to have received the prestigious ISO 9001 Certification and BIS Certification. This certification is recognition of the quality that goes into every step of the manufacturing processes that result in the final weighing scale emerging from the factory. Quality of workmanship and solid customer support are two pillars on which our company rests.

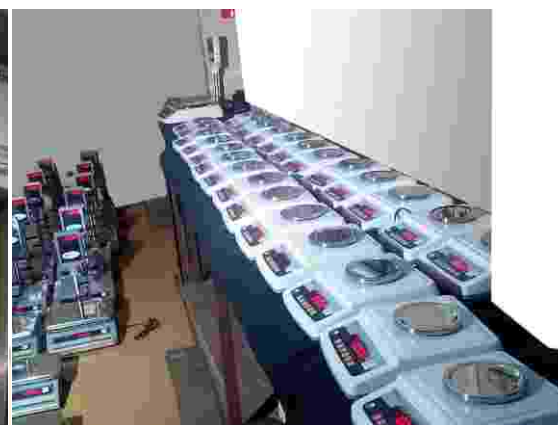

IS9281:PART-3:1981



CM/L7800023609



About us

Knox Electronics Mumbai based organization that manufactures and markets weighing scales and provides after-sales support. Our manufacturing facility is located in the Val Village BHIWANDI, MAHARASHTRA, INDIA. The company's products are sold and supported under the brand name - RUDRA AND KNOXE. (Incidentally, "Rudra" in ancient Sanskrit language stands for "magnificent", "huge".)

The company's promoter brings to the organization an in-depth experience of twenty five years plus in the field of weighing scales. What started as a ONE-MAN organization is today a strong team of dedicated professionals - right from manufacturing to marketing to customer support.

The extended family of Knox Electronics includes its network of dealers, built assiduously through years of hard work. Every dealer is connected to the head office on a 24 X 7 communication link, to provide customers with anytime, anywhere support.

Our Product Ranges are segmented as:

BABY SCALES ● ADULT & CHILD WEIGHING SCALE ● LABORATORY SCALES ● JEWELLERY SCALES
INDUSTRIAL TABLE TOP ● BENCH TYPE ● HERCULES TYPE ● BLUE TOOTH SYSTEMS ● WIFI INDICATORS
PRICE COMPUTING SCALES ● FULLY WATER PROOF SCALES ● RUDGED PLATFORM SCALES WITH 2 inch INDICATOR
FULLY ELECTRONIC WEIGHBRIDGE FROM 5 TONS TO 150 TONS ● WEIGHBRIDGE CONVERSION TO ELECTRONICS
TANK WEIGHING SYSTEMS ● CHECK WEIGHING / SIGNAL TOWER CONNECTION



ELECTRO MAGNET FORCE COMPENSATION SCALES

For Jewellers, Laboratory, Industry, Diamond Merchants

Pan Size : 100 mm

Product description:

Bright LED display | Linearity from least count to capacity
Automatic Zero tracking | Stainless Steel weighing Pan
Membrane Key pad with Tactile switches

Options : Extra Display , Wind Shield, RS232

MAX	350g	600g	1000g	300g	600g
e	0.01g	0.01g	0.01g	0.001g	0.001g

Medium and high accuracy are optional



DUST PROOF/ WATER RESISTANT ABS WRMODEL

Platter Size : 230 x 175mm

Product description:

New Compact Look.
Overload Protection 150% | Environment protected Loadcell
Bright LED Display Red / Green
Fast response and accurate result
Piece Counting/ Zero tracking function

MAX	1Kg	2Kg	5Kg	10Kg	20Kg
e	0.1g	0.2g	0.5g	1g	2g

Medium and high accuracy are optional



LAB / JEWELLERY BALANCE LOADCELL BASED

Pan Size : 100 mm

Product description: Loadcell Technology of Class II
Overload protection and Indication | Bright LED display.
Tare function upto full capacity | Stainless Steel weighing Pan
Automatic Zero tracking | Inbuilt Battery Backup 6V 1.3 AH
Linearity from least count to capacity

Options : Wind Shield, Extra Display, RS232

MAX	300g	600g	1000g	300g	500g
e	0.01g	0.01g	0.01g	0.001g	0.001g

Medium and high accuracy are optional



ABS SMALL TABLETOP

Platter Size : 230 x 175mm

Product description: New Compact Look.

Overload Protection 150% | Environment protected Loadcell
Bright LED Display Red / Green | Stainless Steel Platter
Fast response and accurate result | Battery Backup
Piece Counting/ Zero tracking function

Options : Wind Shield, Extra Display, RS232

MAX	1Kg	2Kg	5Kg	10Kg	20Kg
e	0.1g	0.2g	0.5g	1g	2g

Medium and high accuracy are optional



JEWELLERY SCALE WHITE BACKLIGHT

Pan Size : 100 mm

Product description:

With Extra Display,
With Battery
FREE 500g SS weight
Plastic windshield

MAX	600g	1200g	2000g
e	0.01g	0.01 g	0.01 g



TABLE TOP SCALES SMALL METAL CABINET

Platter Size : 250 x 200 mm

Product description:

Metal Rugged Body | Overload Protection 150%
Environment protected Loadcell | Bright LED Display Red / Green
Fast response and accurate result | Stainless Steel Platter
Piece Counting/ Zero tracking function | Battery Backup

Options : On mac/ Rod Type/ Wire Type.

MAX	1Kg	2Kg	5Kg	10Kg	20Kg
e	0.1g	0.2g	0.5g	1g	2g

Medium and high accuracy are optional



TABLE TOP SCALES MOULDED NEW: Metal

Platter Size : 300 x 250 mm

Product description: Metal Rugged Body
 Overload Protection 150% | Environment protected Loadcell
 Bright LED Display Red / Green | Stainless Steel Platter
 Fast response and accurate result
 Piece Counting/ Zero tracking function | Battery Backup
Options : On mac/ Rod Type/ Wire Type.

MAX	2Kg	5Kg	10Kg	20Kg	30Kg
e	0.2g	0.5g	1g	2g	5g

Medium and high accuracy are optional



SWIFT MODEL

Platter Size : 260 x 220 mm

Product description:
 Ultra Power Saving 1 charge 200 days.
 Durable Construction (500% overloading resist)
 Embossed Membrane Keyboard. | Rugged machine.
 Battery Level discrete Indicator.
Options : ROD TYPE, WIRETYPE, RS232

MAX	10Kg	20Kg	30Kg
e	1g	2g	5g

Medium and high accuracy are optional



Hand Fabricated TABLE TOP SCALES (SL): Metal Cabinet

Platter Size : 300 x 250 mm

Product description: Metal Rugged Body | Overload Protection 150%
 Environment protected Loadcell | Bright LED Display Red / Green
 Fast response and accurate result | Stainless Steel Platter
 Piece Counting/ Zero tracking function | Battery Backup
Options : ROD TYPE, WIRE TYPE, RS232

MAX	2Kg	5Kg	10Kg	20Kg	30Kg
e	0.2g	0.5g	1g	2g	5g

Medium and high accuracy are optional



FULLY WATER PROOF LED ABS cabinet

Platter Size :200 x 190 mm

Product description:
 ELECTRONIC PARTS ALL FULLY WATER PROOFED
 BRIGHT LED
 EMBOSSED MEMBRANE KEYBOARD
Options : Wind Shield, Extra Display RS232

MAX	10 Kg	20 Kg	30 Kg
e	1 g	2 g	5 g



JUMBO TABLE TOP SCALES

Platter Size : 370 x 325 mm

Product description: Metal Rugged Body
 Overload Protection 150% | Environment protected Loadcell
 Bright LED Display Red / Green | Stainless Steel Platter
 Fast response and accurate result | Battery Backup
 Piece Counting/ Zero tracking function
Options : ROD TYPE, WIRETYPE, RS232

MAX	30 Kg	50 Kg
e	2 g	5 g

Medium and high accuracy are optional



FULLY WATER PROOF PRICE COMPUTING SCALES

Platter Size :290 x 220mm

Product description: Ultra Power Saving 1 charge 200 days.
 Durable Construction (500% overloading resist)
 Galvanized dual frame(7 year roast resist)
 Price Computing, Preset Tare, Accumulation | Dust Cover.
 Counting PCS function in Base | Give Change Function.
 Embossed Membrane Keyboard | Rugged machine.
 Battery Level discrete Indicator | Stainless Steel Pan

MAX	10 Kg	20 Kg	30 Kg
e	1 g	2 g	5 g



Cash Register Printing Scale



KEY PARAMETERS

- ❖ **Precision**
1/3000
- ❖ **Weighing scope**
0-6Kg-15Kg or 0-15-30Kg
- ❖ **Weighing Resolution (e)**
2/5 g or 5/10 g
- ❖ **Storage Capacity**
1000 PLUs
- ❖ **Display**
Double sides displays with the pole, LED Digital Tube: Red,5/5/6 digits(Weight/Unit Price /Total Price)
- ❖ **Keyboard**
55 keys (30x2=60 PLU Hotkeys,25 Function keys)
- ❖ **Printing Type**
Thermal Printing, Printing Speed:> 50mm/s,Printing Width : 48mm, Paper Roll:57.5 ± 0.5mmx Ø50mm
- ❖ **Communications Ports**
1xRS232 , 1XRJ11 for cash Drawer, USB(Atype) for U-Disk.
- ❖ **Power Supply**
Input: AC 100-240V 50/60 Hz ,Output DC7.5V/3A
- ❖ **Build-in-battery**
6V/4A
- ❖ **Dimension(MM)**
325 (w) X 385(d) X 130(H) (The Height is 435 mm including display pole)
- ❖ **Net weight**
About 4.5 kg
- ❖ **Work environment**
Temperature :- 10°C-40°C ,Humidity : 20 % - 90 % RH
- ❖ **Storage Environment**
Temperature :- 20°C-50°C ,Humidity : 10 % - 95% RH

Function & Features

1,000 PLUs Storage capacity.

Has 60(30x2) Hotkeys,easy for calling out the goods for sale.

Connect with U-Disk for adding reports storage,stock each receipt detailed content and daily report.

Using special PC Software,setup and print the keyboard hotkeys distribution,inserting the paper of hotkeys distribution into the keyboard hotkeys area below,intutive operation fast.

Daily report query and print functions.

A bill may be accumulated continuously weighing 50 goods

Re-print the last receipt.

Support the weighing sales and quantity sales.

Support change , Tare,Zero,Add,Back space,cancel,Print,Open cash drawer, and other Functions.

Setting the machine's date and time and date.

Setting receipt head and tail titles

Transfer the receipt head and tail titles by U-DISK OR RS232 port, and can manage all the data by the PC software which in the CD

Cash Register Printer Advance Scale



Function & Features

10,000PLUs storage capacity, support up to 60,000 PLUs by increase memory capacity

Has 60(30x2)Hotkeys,easy for calling out the goods for sale.

Using special PC Software, setup and print the keyboard hot-keys distribution, inserting the paper of hot-keys distribution into the keyboard hot-keys area below, intuitive operation fast.

Daily report session reports and other report query and print fruitions.

A bill may be accumulated continuously weighing 50 goods.

Two kinds of sales model:3 customers checkout in the same time or just one customer checkout.

Support up to 99 user,99 departments, and you can set the scales's ID NUMBER (0-9999). Flexibility to set user permissions, empowering user to manage, protects data security.

Support the weighting sales and quantity sales.

KEY PARAMETERS

- ❖ **Precision** - 1/3000
- ❖ **Weighing scope** - 0-6Kg-15Kg or 0-15-30Kg
- ❖ **Weighing Resolution** - 2/5 g or 5/10 g
- ❖ **Storage Capacity**- 10,000 PLUs , support up to 60,000 PLUs by increase memory capacity.
- ❖ **Display**- Double sides display with pole.LCD: 128 X 48 dots (21 letters x 4 lines, White back light) , just operator display has it. LED Digital Tube: Red ,5/5/6 digits (Weight /Unit Price /Total Price)
- ❖ **Keyboard**- 60 Keys (30x2=60 PLU Hot-keys , 30 Function keys)
- ❖ **Printing Type**- Thermal Printing ,Printing Speed :> 50 mm/s, Printing Width : 48 mm, Paper Roll : 57.5±0.5mm x Ø50mm
- ❖ **Ports (Standard)**- 1 x RS232 , 1 X PS/2 for Barcode Scanner,1 x RJ11 FOR Cash Drawer , 1xRJ45 Ethernet❖ **Ports (Optional)**- 1 x USB (A Type) for U-Disk.
- ❖ **Power Supply**- Input : AC 100-240V 50/60 Hz, Output : DC 7.5V/3A
- ❖ **Build-in-battery**- 6V/4A
- ❖ **Net weight**- About 5.2 Kg
- ❖ **Dimension(MM)**- 367 (W) X 410 (D) X 125 (H) (The height is 460 mm including display pole)
- ❖ **Work environment**- Temperature :- 10°C-40°C ,Humidity : 20 % - 90 % RH
- ❖ **Storage Environment**- Temperature :- 20°C-50°C ,Humidity : 10 % - 95% RH

According to user needs, to print multiple copies or re-print the last receipt.

Have change ,Tare , Zero, Add, Quick revert , Cancel input , Void one ,Void all ,Print , and other Functions.

Many sales type :PLU discount, one receipt discount, premium, coupons, service fees, and temporary price change, etc.(by amount or percentage methods)

Have R/A and P/O functions, purchase & return goods functions, Calculator functions, cash drawer opens function.

Setting the machine's date and Time, scrolling shown information display when machine standby

Setting receipt's head and tail titles, head and tail LOGO, title words size and printing colour depth etc.

Connect with the computer by RS232 serial port or RJ45 Ethernet port and can set PLUs, hot-keys, receipt form machine's parameters and many kind of data upload or download by the PC software which in the CD

Support transfer the data to center data server automatically and query the details trade data and statistics data by IE web browser via LAN or WAN.(Optional)

Label Printing Scale



KEY PARAMETERS

- ❖ **Precision**
1/3000
- ❖ **Weighing scope**
0-6Kg-15Kg or 0-15-30Kg
- ❖ **Weighing Resolution (e)**
2/5 g or 5/10 g
- ❖ **Storage Capacity**
10000 PLUs
- ❖ **Display**
Double sides displays with the pole, 26 LED Display.
- ❖ **Keyboard**
140 keys (112x2=224 PLU Hot-keys, 28 Function keys)
- ❖ **Printing Type**
Thermal Printing , Printing Speed: >50mm/s, Printing Width : 56mm (MAX),
- ❖ **Label Paper Roll**
Width (Max) : 58±0.5mm, Outer diameter 80 mm (Max) , internal Diameter : 40 mm (Min)
- ❖ **Label Size**
Width : 30 mm-58mm, Length 25mm-48mm, Recommended label size : 58mm(W)x37mm(L)
- ❖ **Communications Ports**
1xRS232 , 1XRJ45 Ethernet
- ❖ **Power Supply**
AC 100-120V or AC 200-240V 50/60 Hz.0.5A
- ❖ **Build-in-battery**
Without
- ❖ **Dimension(MM)**
360 (w) X 440(D) X 175(H) (The Height is 490 mm including display pole)
- ❖ **Net weight**
About 8.5 kg
- ❖ **Work environment**
Temperature :- 10°C-40°C , Humidity : 20 % - 90 % RH
- ❖ **Storage Environment**
Temperature :- 20°C-50°C , Humidity : 10 % - 95% RH

Function & Features

Big storage capacity : 10,000 plus data storage capacity, plus extra storage optional

224 (112X2)PLU hot-keys, easy for calling out the products, computer setting and printing hot-keys

Different type of selling : weighing , default price and weight selling

Could set print parameters, barcode formats according customized.

Support automatic printing

Powerful Network communication : Programme setting , multiple-machine network, back-office management via RS-232 OR Ethernet (TCP/IP)

Easy programming: PLUs database, label barcode format, systems parameters, hot-keys, 8 letter strings, 255 explanations to be edited in pc or directly in scale.

Various special selling modes : discount in percentage or coupon, additional charge in percentage or other extra charge, change price anytime ect



**CHICKEN / BENCH/ MOBILE SCALE
Stainless Steel**

Product description:
 EASY TO HANDLE AND CARRY.
 BRIGHT LED DISPLAY
 OVERLOAD PROTECTION
 STAINLESS STEEL PLATTER
 BATTERY BACKUP
 AUTO ZERO TRACKING
 PUSH BUTTON KEYS/ MEMBRANE KEYPAD

Capacity	Accuracy	Platter Size
50 kg	5 g	300x 300 mm
100 kg	10 g	400 X 400 mm
200 kg	20 g	400 X 400 mm
300 kg	50 g	500 X 500 mm

Medium and high accuracy are optional



**BENCH/ MOBILE/ CHICKEN SCALE CHECKERED
Mild Steel**

Product description:
 EASY TO HANDLE AND CARRY.
 BRIGHT LED DISPLAY
 OVERLOAD PROTECTION
 MS CHECKERED PLATTER
 BATTERY BACKUP
 AUTO ZERO TRACKING
 PUSH BUTTON KEYS/ MEMBRANE KEYPAD

Capacity	Accuracy	Platter Size
100 kg	10 g	400 X 400 mm
200 kg	20 g	400 X 400 mm
300 kg	50 g	500 X 500 mm

Medium and high accuracy are optional



FLAME PROOF ENCLOSURE

PESO APPROVED
 CSIR. CIMFR Dhanbad APPROVED

Size available
 200 X 200 mm
 250 X 250 mm
 300 X 300 mm



HEAVY PLATFORM SCALES

Product description:
 HEAVY STRUCTURE
 BRIGHT LED DISPLAY
 OVERLOAD PROTECTION
 STAINLESS STEEL / MS CHECKERED PLATTER
 TARE FUNCTION UPTO FULL CAPACITY
 LINEARITY FROM LEAST COUNT TO CAPACITY
 LOW POWER INDICATION
 BATTERY BACKUP
 AUTO ZERO TRACKING | MEMBRANE KEYPAD

Capacity	Acc.	M S Checkered Platter Size	LC	Structure
500kg	50g	750 X 750 410 mm	1	Pipe 40 x 40 L
1 ton	100 g	750 X 750 410 mm	1	C Channel 3 x1.5
1 ton	100 g	900 X 900 mm	1	Pipe 50 x 50
2 ton	200 g	900 x 900 mm	1	C channel 3 x 1.5
1 ton	100 g	1000 x 1000 mm	4	C channel 3 x 1.5
2 ton	200 g	1200 X 1200 mm	4	C channel 3 x 1.5
3 ton	500 g	1500 x 1500 mm	4	C channel 5 x 2.5

Medium and high accuracy are optional



PLATFORM SCALES

Product description:
 HEAVY STRUCTURE
 BRIGHT LED DISPLAY
 OVERLOAD PROTECTION
 STAINLESS STEEL / MS CHECKERED PLATTER
 TARE FUNCTION UPTO FULL CAPACITY
 LINEARITY FROM LEAST COUNT TO CAPACITY
 LOW POWER INDICATION
 BATTERY BACKUP
 AUTO ZERO TRACKING
 MEMBRANE KEYPAD

Capacity	Accuracy	Platter Size
30/60 kg	5 g /10 g	300 X 300 mm
50/100 kg	5 g /10 g	400 X 400 mm
60/150 kg	10 / 20 g	450 X 450 mm
100/200 kg	10/20 g	500 X 500 mm
100/200 kg	10/20 g	500 X 500 MSCH
300 kg	50 g	600 X 600 mm
300 kg	50 g	600 X 600 MSCH
500 kg	50 g	600 X 600 mm
500 kg	50 g	600 X 600 MSCH
500 kg	50 g	600 X 600 Bending MSCH
500 kg	50 g	600 X 600 mm (Angle) MSCH
500 kg	50 g	500 X 500 600 X 600 mm (C Channel) MSCH

Medium and high accuracy are optional



WHEEL PLATFORM SCALES

Product description:
 SUITABLE FOR INDUSTRY, MARKET YARD etc
 HEAVY STRUCTURE EASY TO MOVE
 BRIGHT LED DISPLAY | OVERLOAD PROTECTION
 STAINLESS STEEL / MS CHECKERED PLATTER
 TARE FUNCTION UPTO FULL CAPACITY
 LINEARITY FROM LEAST COUNT TO CAPACITY
 LOW POWER INDICATION | BATTERY BACKUP
 AUTO ZERO TRACKING | MEMBRANE KEYPAD
 WHEEL OPTION WITH CASTOR OR METAL
 HANDLE TO SLIDE

Capacity	Accuracy	Platter Size
60/150 kg	10/20 g	500 X 500 mm
300 kg	50 g	600 X 600 mm
500 kg	50 g	700 X 450 mm

Medium and high accuracy are optional



BABY CUM ADULT WEIGHING SCALE

Baby weighing Platter size: 550 x 265 mm
Adult Weighing Platter size: 450 x 450 mm (SS)

Product description:
 Very Convenient and accurate
 ABS material used for weighing INFANT
 Easy to weigh adults



Max	20kg	100kg	200 kg	300 kg
e	10 g	50 g	100 g	100g

Hanging Scales

MAX	60Kg
e	10 g



MAX	100 Kg	200 Kg
e	10 g	20 g



MAX	300 Kg	500 Kg
e	50 g	100 g



HEAVY CRANE SCALE WITH REMOTE

Product description:

30 mm LED Display
NEW DESIGN PCBAND LONGER STANDBY TIME.
INTEGRAL DESIGN OF LOADCELL, QUICK, ACCRATE,
STABLE WEIGHING
HIGH QUALITY RECHARGEABLE BATTERY AND IMPACT
RESISTANT ALUMINIUM ALLOY CASTING
CONVENIENT REMOTE CONTROLLER

MAX	20 t	30 t
e	2kg	5kg



CRANE SCALE HEAT DEFENDER

Max	1 t	2 t	3 t	5 t
e	0.2kg	0.5kg	1kg	2kg

Range	1000°C	1200° C	1400° C	1500° C
Safe Distance	1200mm	1500 mm	1800 mm	2000 mm



PRICE COMPUTING SCALES

Platter Size : 300 x 250 mm

Product description: Metal Rugged Body

Overload Protection 150%

Environment protected Loadcell | LED Display Red / Green

Fast response and accurate result

Price Computing 49 Memory | Zero tracking function

Stainless Steel Platter | Battery Backup

Options : ROD TYPE, WIRETYPE, RS232

MAX	2Kg	5Kg	10Kg	20Kg	30Kg
e	0.2g	0.5g	1g	2g	5g

Medium and high accuracy are optional



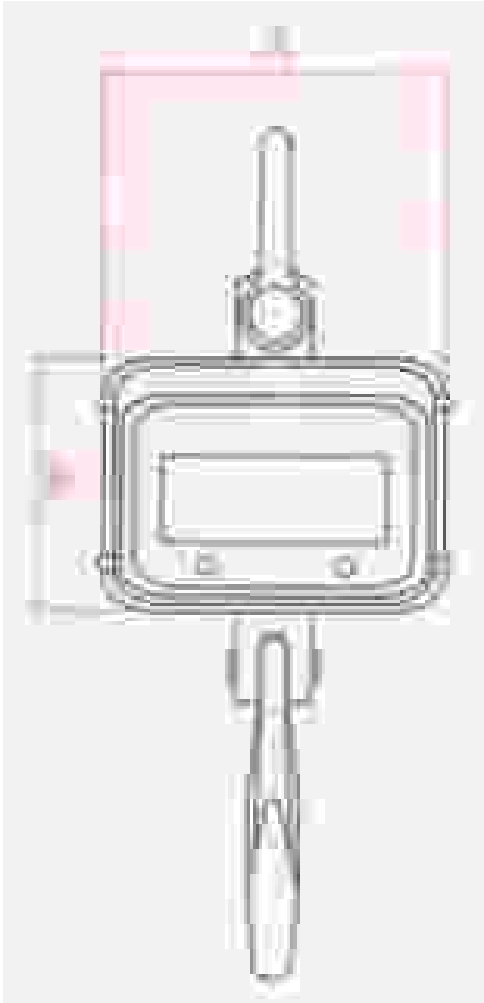

CRANE SCALE WITH REMOTE

Product description: 30 mm LED display
 NEW DESIGN PCBAND LONGER STANDBY TIME.
 INTEGRAL DESIGN OF LOADCELL, QUICK, ACCRATE,
 STABLE WEIGHING
 HIGH QUALITY RECHARGEABLE BATTERY AND
 IMPACT RESISTANT ALUMINIUM ALLOY CASTING
 CONVENIENT REMOTE CONTROLLER

MAX	1 t	2 t	5 t	10 t
e	0.2kg	0.5kg	1kg	2kg

Model	Full Scale kg	Division kg	Number of Division	Dimension mm								Weight kg
				A	B	C	D	E	F	G	H	
KHS-2T	2000	1	2000	255	190	205	580	70	67	46	35	13.5
KHS-3T	3000	1	3000	255	190	205	580	70	67	46	35	13.5
KHS-5T	5000	2	2500	255	190	205	680	88	73	60	45	18.5
KHS-10T	10000	5	2000	255	190	205	780	114	92	71	59	30



TANK WEIGHING SYSTEMS

Product description:
Micro controller based systems
Systems as per your requirement.
From 1 Tons to 20 Tons.
Horizontal and Vertical Tanks
Power On weights
Recall Old Calibration

We offer complete Batching software with PLC or PC integration.

Options : Options: RS 232 / RS 485 | 4-20 mA with independent calibration | Remote Display

Table Top and Platform Scales STAINLESS STEEL GRADE 202, 304, 316



Hand Fabricated Table Top Scale/ Platform Scales with 304 Stainless Steel
For all Kind of Application | All Allen Bolt, Screw and Hardware also of 304 quality.
We also produce Platforms and Table Tops with Stainless Steel 316 grade

ELECTRONIC WEIGH BRIDGE

Product description:
Lorry Weigh Bridge upto Capacity 150 Tons
Load cells : Analogue and Digital
asper Customers Choice.
Intelligent Terminal and Computer
Interface both available.



Options: RS232/ RS485 | SMS facility | CCTV connectivity | Jumbo Display.



PRINTER INDICATOR

Product description:
Weighing Indicator with Printer
Prints the weighment
Header for Name and Address of the Party
Footer for Welcome or Thanks
Serial no. wise report
Date wise report



TOWER LIGHT (SET POINT)

Product description:
Check weighing with tower light and buzzer.
Very convenient and fast production
Available in all models TableTop and Platform



BLUETOOTH INDICATOR

Product description:
Connectivity through blue tooth on
Android Mobiles
Any capacity or accuracy selectable
Can operate from mobile or machine
Memory function
Tare function



GRADE TABLE TOP

Product description:
Sorting machine.
Instant calculates the grade of Mangoes,
Oranges etc.

Our Proud Customers



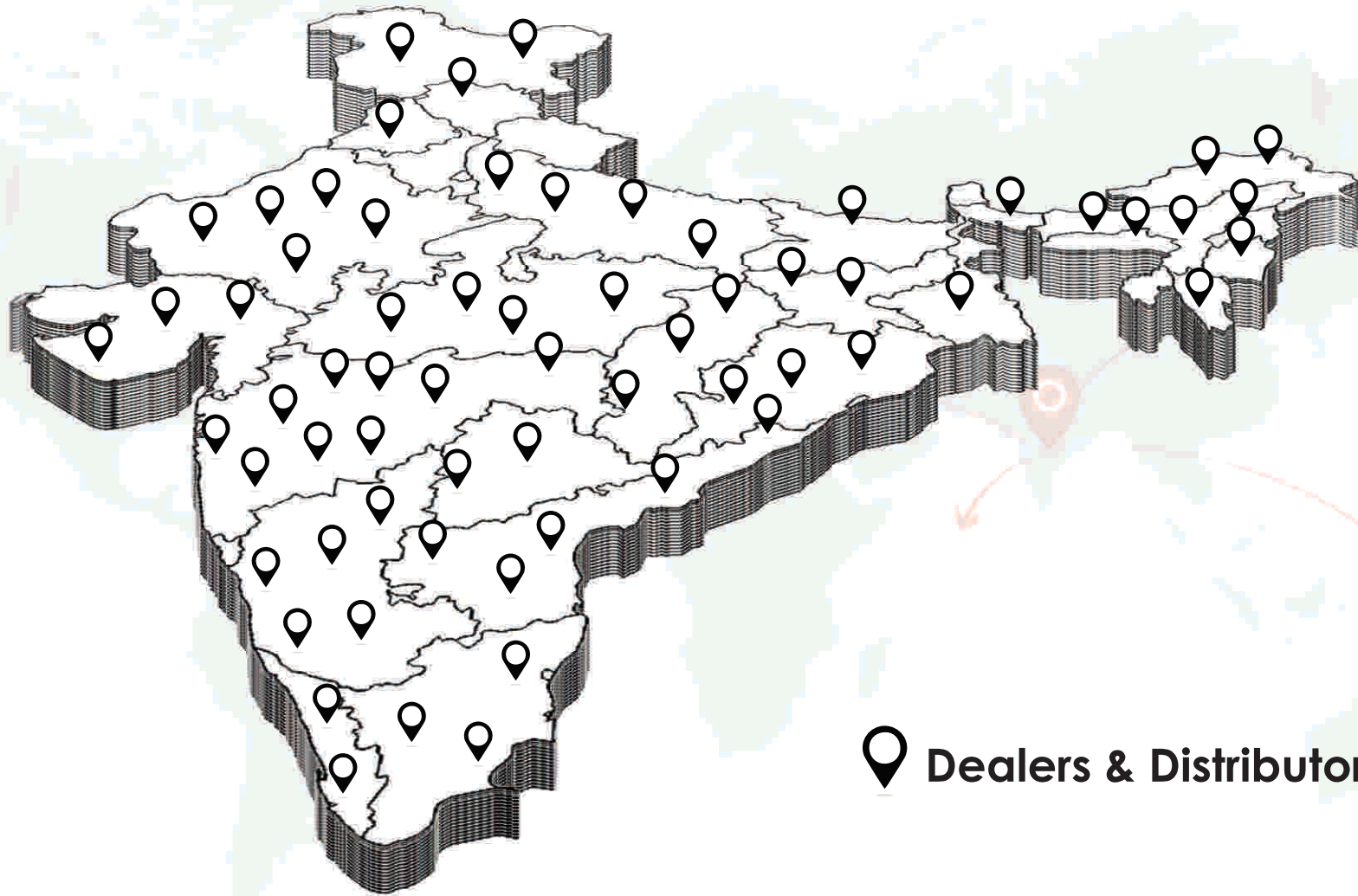

 Dealers & Distributors

Knox[®] | **Rudra**
ELECTRONICS
House of Weighing...



ISO 9001:2015
CERTIFIED



Knox Electronics

SB-155, 2nd Floor, High Street Mall, Kapurbawadi, Thane (w) - 400 607

Tel.: +91 22 2544 9311 / 2544 8256 Mob.: 9224551950 | knoxescales@gmail.com | rudrascales2007@gmail.com

Factory - Bhiwandi-421 302 , Dist Thane | www.rudrascales.com | www.knoxescales.com